

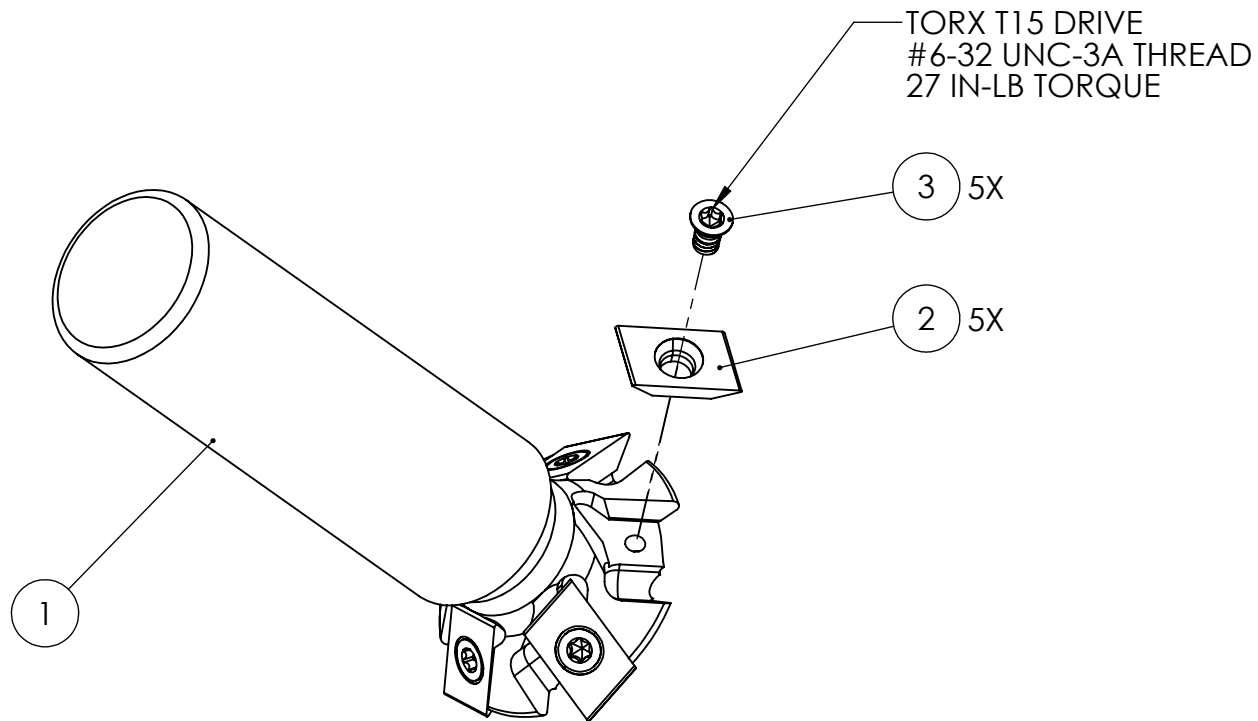

**MATERIAL: H13 TOOL STEEL**  
**COMPATIBLE WITH ALL 5TH AXIS DOVETAIL PRODUCT**

# DC1750-M

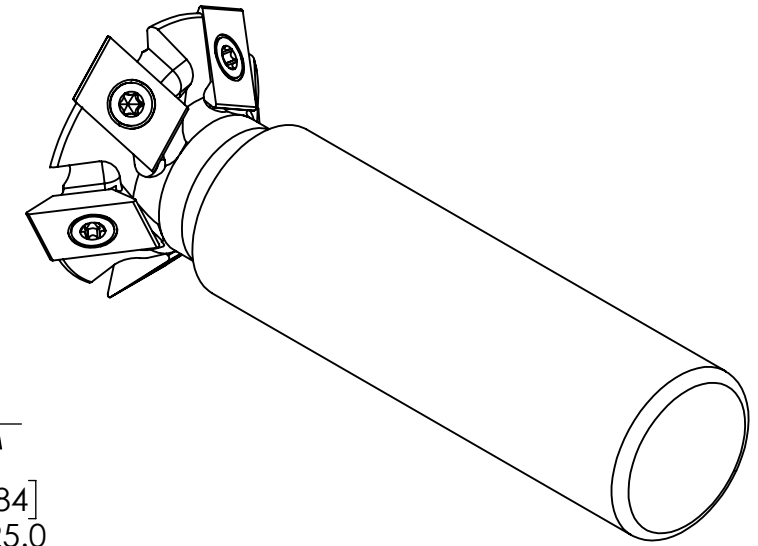
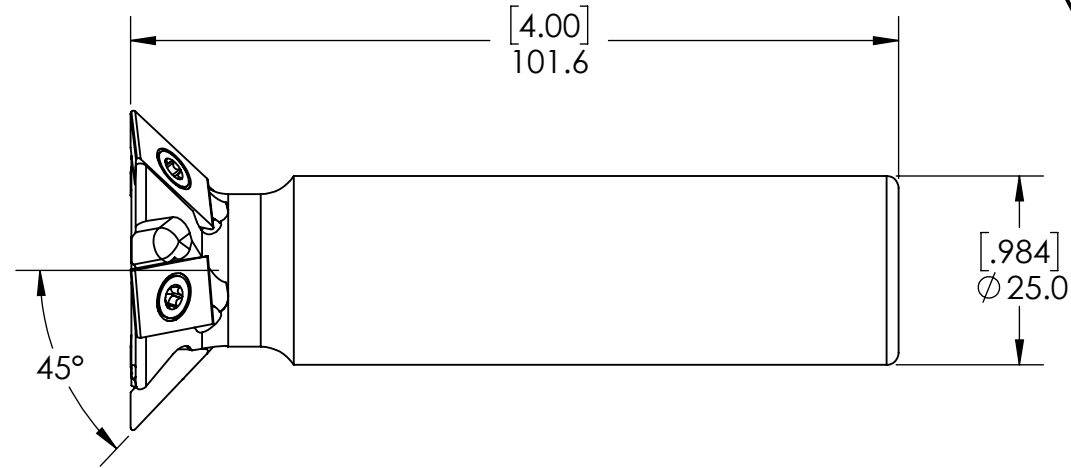
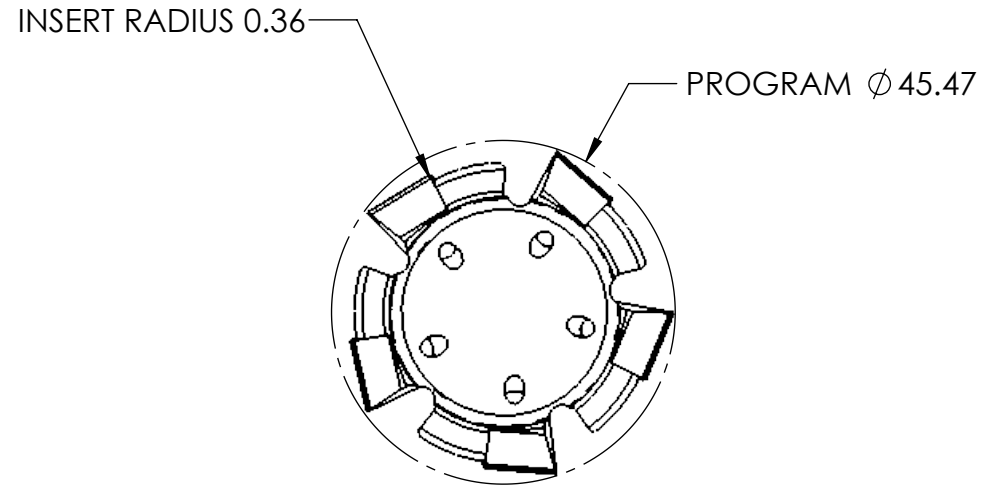

ITEM NO.	PART NUMBER	DESCRIPTION	QTY.
1	DC1750M-45B	DOVETAIL CUTTER BODY	1
2	DC1750-B	DOVETAIL CUTTER INSERTS	5
3	DC1750-S	DOVETAIL CUTTER SCREWS	5

<b>METRIC</b> WWW.5THAXIS.COM 7140 ENGINEER ROAD SAN DIEGO, CA 92111 P (858) 505-0432			
	DESCRIPTION <b>DOVETAIL CUTTER, 45°</b>		
THIRD ANGLE PROJECTION	SIZE <b>B</b>	PART NO. <b>DC1750-M</b>	REV <b>B</b>
DO NOT SCALE DRAWING		SCALE 1:1	WEIGHT: SHEET 1 OF 1