

8

7

6

5

4

3

2

1

TECHNICAL DATA	V510X
JAW WIDTH	125.73mm
BASE LENGTH	260.00mm
MAXIMUM TORQUE (JAW BOLT)	47.45 Nm
CLAMPING FORCE	25.13kN @ 74.57 Nm
MAXIMUM TORQUE (LEADSCREW)	74.57 Nm
MAXIMUM TORQUE (MOUNTING BOLT)	47.45 Nm
SELF-CENTERING ACCURACY	± 12.7µm

# V510X

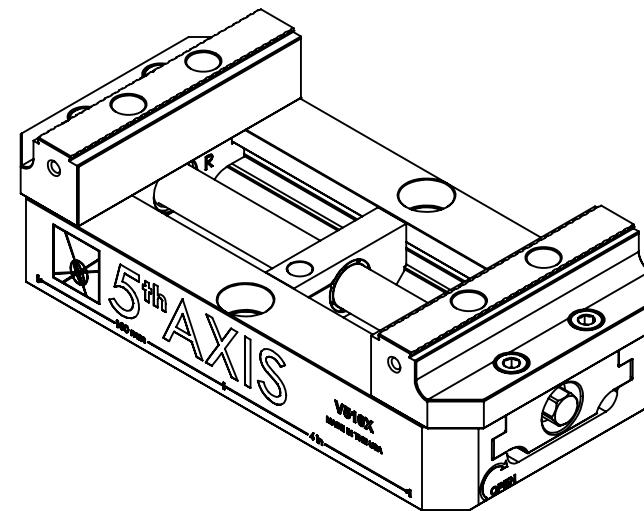

D

D

C

C

B

B

A

A

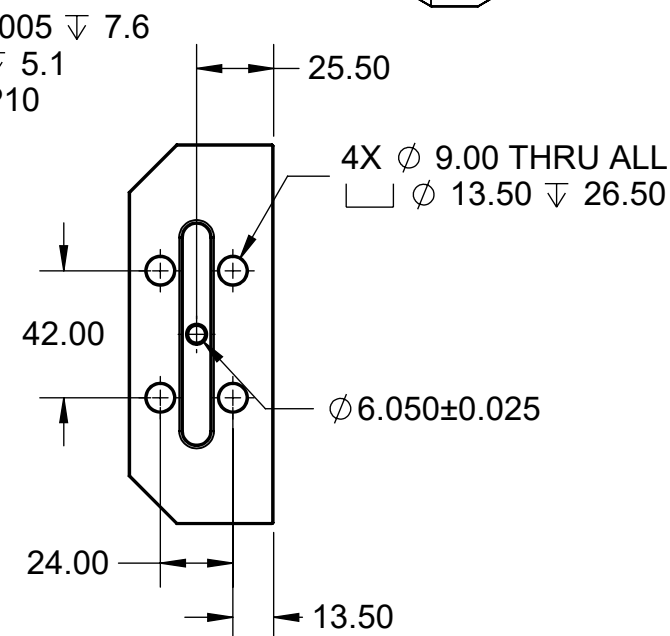
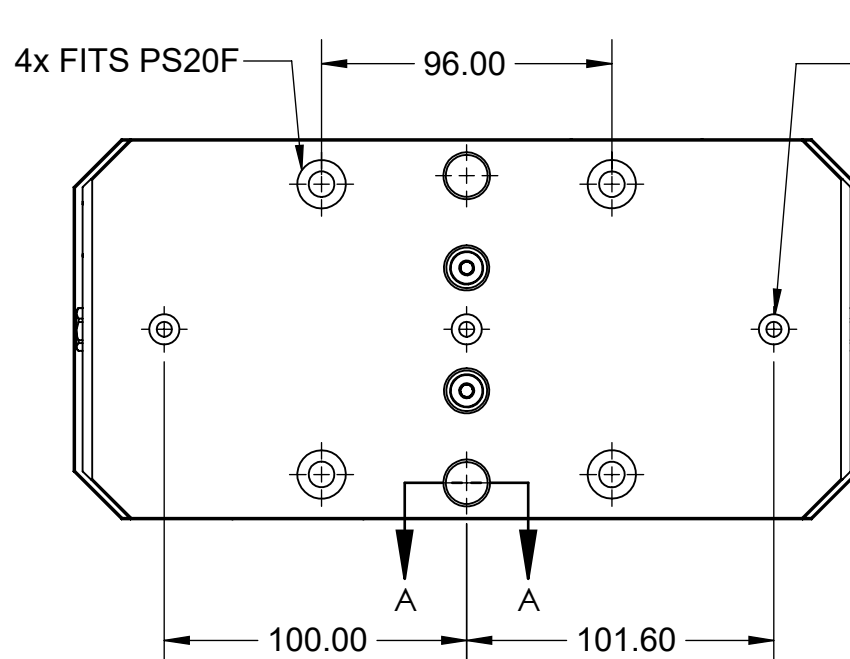
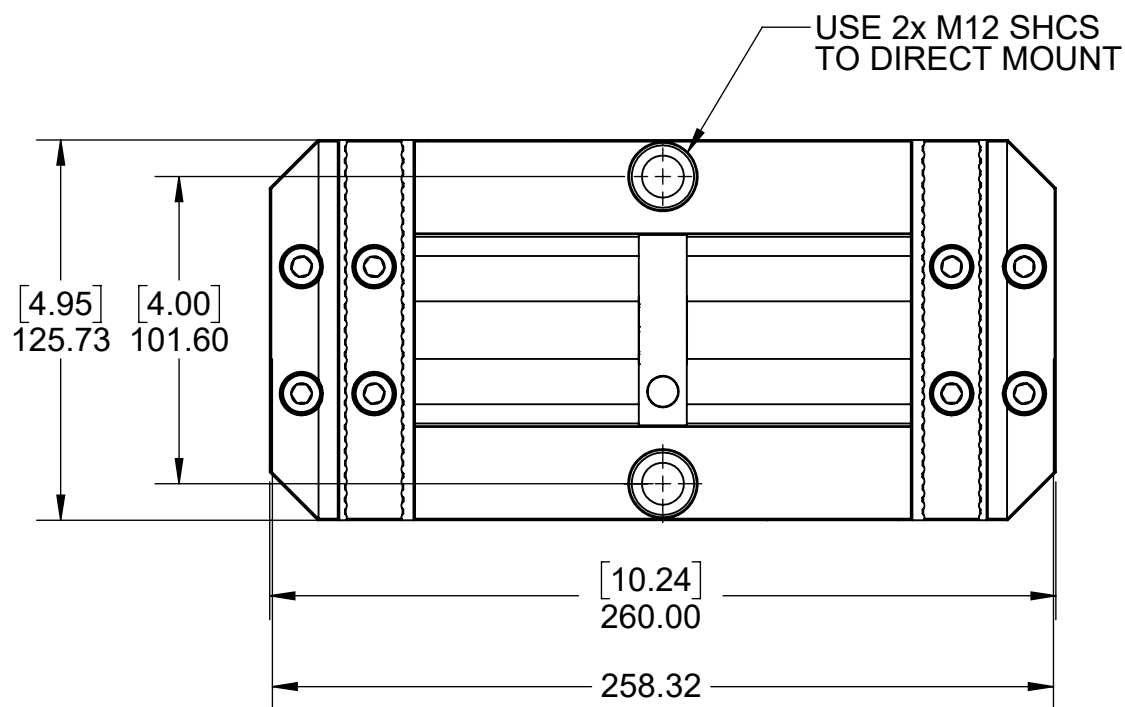

JAW MOUNTING

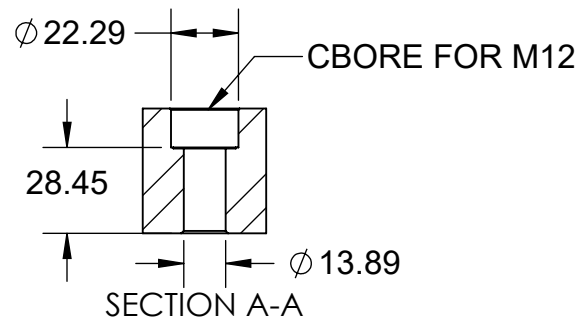
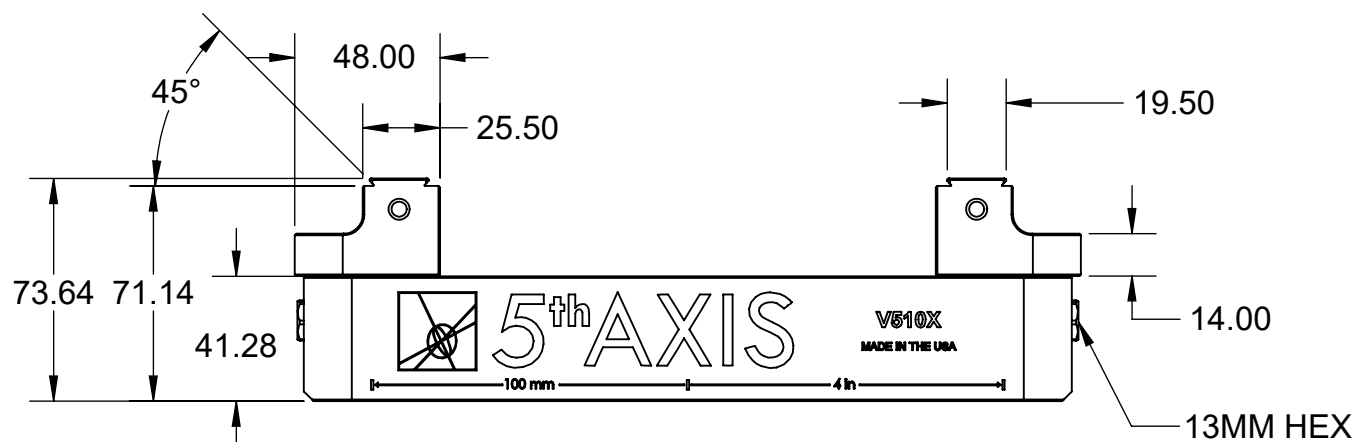

<b>MILLIMETER</b> <small>DRAWN IN ACCORDANCE WITH ASME Y14.5-2009</small>  <small>WWW.5THAXIS.COM</small>  <small>7140 ENGINEER ROAD SAN DIEGO, CA 92111</small>  <small>P (858) 505-0432 F (858) 505-9344</small>	<b>TOLERANCES</b> <small>UNLESS OTHERWISE SPECIFIED</small> x ± 0.1    .xx ± 0.01 .x ± 0.05    .xxx ± 0.005 ANGULAR ± 0.5° <small>THIRD ANGLE PROJECTION</small>			<small>DESCRIPTION</small> <b>LARGE SELF-CENTERING VISE</b>		
				<small>SIZE</small> <b>B</b>	<small>PART NO.</small> <b>V510X</b>	<small>REV</small> <b>A</b>

8

7

6

5

4

3

2

1

D

D

# V510X

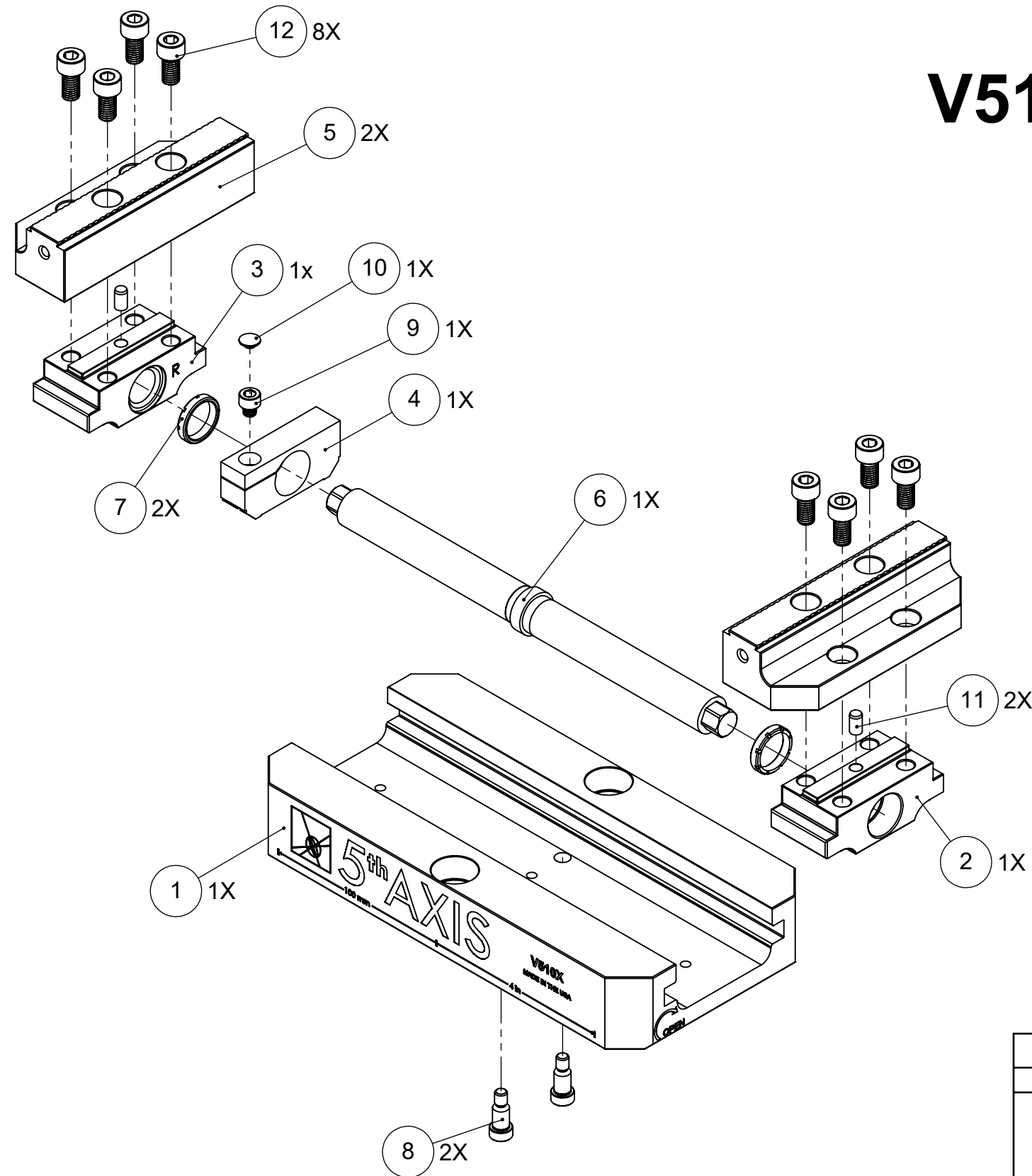

ITEM NO.	PART NUMBER	DESCRIPTION	QTY.
1	V510X-1	BASE	1
2	V562X-2L	LEFT TRUCK	1
3	V562X-2R	RIGHT TRUCK	1
4	V562MX-3	CENTER BLOCK	1
5	V562X-5	JAW	2
6	V5104M-4	LEAD SCREW	1
7	V56124-6	CENTER BLOCK RING	2
8	SB5VX	SHOULDER BOLT	2
9	91290A310	SOCKET HEAD CAP SCREW	1
10	M6C	PLASTIC PLUG	1
11	M6X12.DP	DOWEL PIN, M6 X 12mm	2
12	91290A418	SOCKET HEAD CAP SCREW	8
13	ANTI-SEIZE	ANTI-SEIZE (NOT SHOWN)	1
14	LP10	LOCATING PIN (NOT SHOWN)	2
15	TS13	THUMB SCREW (NOT SHOWN)	1

FOR REFERENCE ONLY - NOT FOR RESALE

C

C

B

B

A

A

<b>MILLIMETER</b> <small>DRAWN IN ACCORDANCE WITH ASME Y14.5-2009</small>  WWW.5THAXIS.COM  7140 ENGINEER ROAD SAN DIEGO, CA 92111  P (858) 505-0432 F (858) 505-9344	<b>TOLERANCES</b> <small>UNLESS OTHERWISE SPECIFIED</small> x ± 0.1    .xx ± 0.01 .x ± 0.05    .xxx ± 0.005 ANGULAR ± 0.5° THIRD ANGLE PROJECTION			
		<b>DESCRIPTION</b> LARGE SELF-CENTERING VISE		
		SIZE <b>B</b>	PART NO. <b>V510X</b>	REV <b>A</b>
DO NOT SCALE DRAWING		SCALE 1:3	WEIGHT:	SHEET 2 OF 3

8

7

6

5

4

3

2

1

**NOTE:** USING DOVETAIL ALLOWS VISE TO CLAMP LARGER PART.  
 BELOW CLAMPING RANGE ONLY SHOWS THE CAPABILITY OF THE GRIPPER TEETH.

# V510X

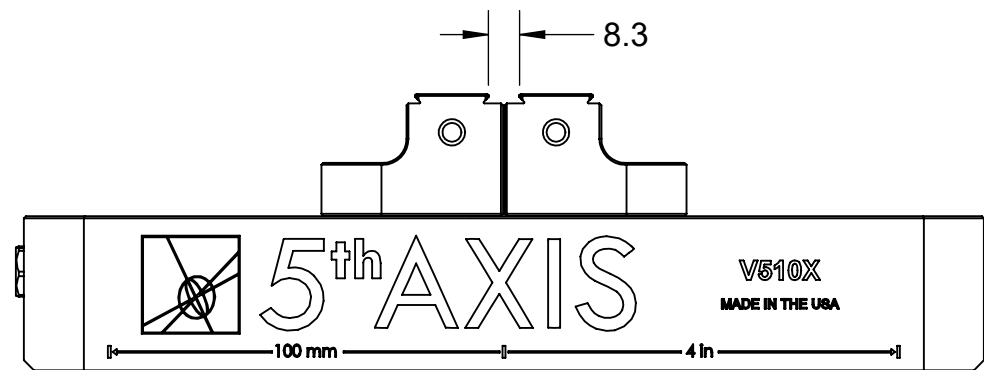

**FORWARD JAWS (MINIMUM CLAMPING RANGE)**

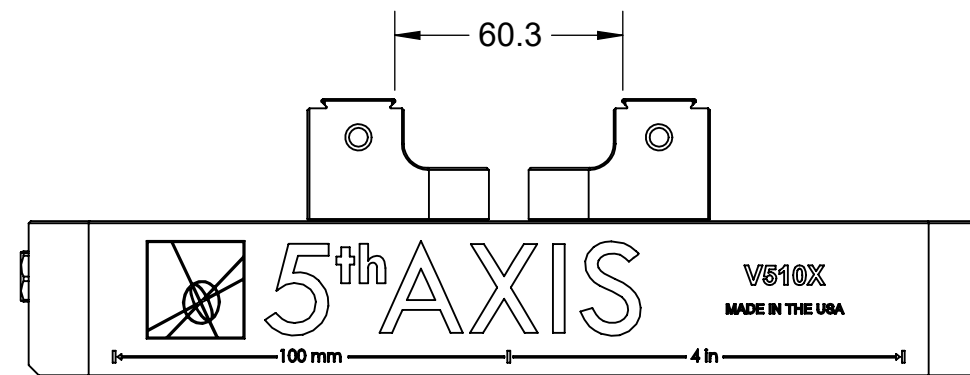

**REVERSE JAWS (MINIMUM CLAMPING RANGE)**

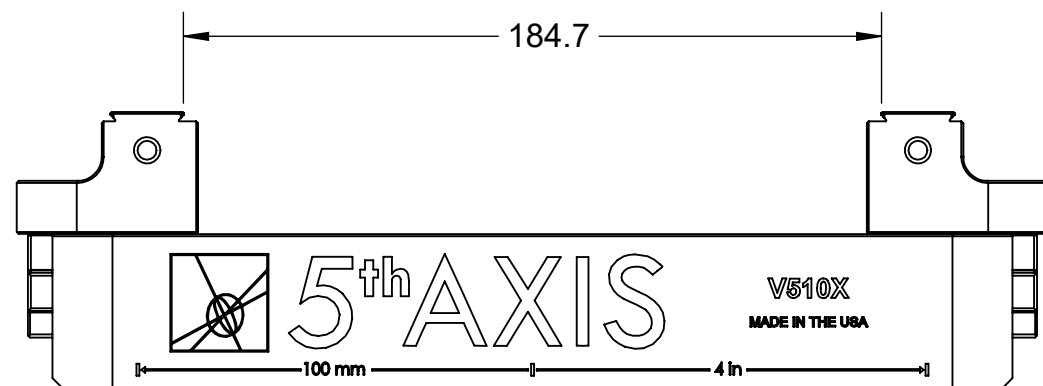

**FORWARD JAWS (MAXIMUM CLAMPING RANGE)**

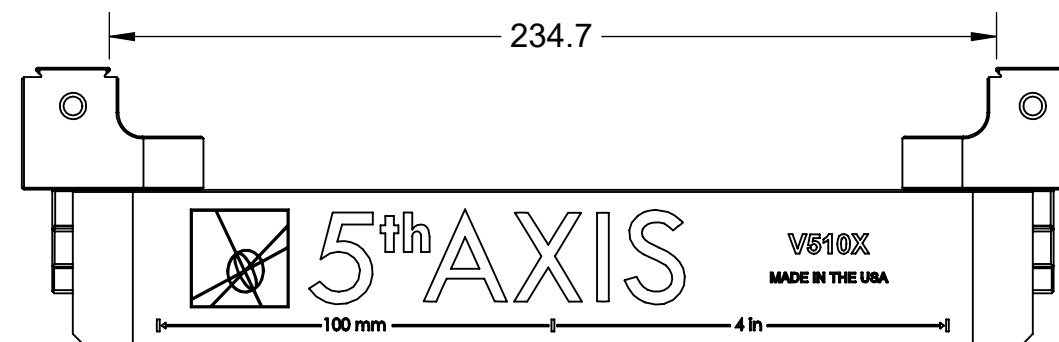

**REVERSE JAWS (MAXIMUM CLAMPING RANGE)**

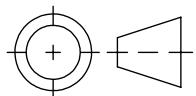
<b>MILLIMETER</b> <small>DRAWN IN ACCORDANCE WITH          ASME Y14.5-2009</small>	<b>TOLERANCES</b> <small>UNLESS OTHERWISE SPECIFIED</small> x ± 0.1    .xx ± 0.01 .x ± 0.05    .xxx ± 0.005 ANGULAR ± 0.5° <small>THIRD ANGLE PROJECTION</small>			
		<b>DESCRIPTION</b> <b>LARGE SELF-CENTERING VISE</b>		
WWW.5THAXIS.COM  7140 ENGINEER ROAD SAN DIEGO, CA 92111  P (858) 505-0432 F (858) 505-9344		<b>SIZE</b> <b>B</b>	<b>PART NO.</b> <b>V510X</b>	<b>REV</b> <b>A</b>
DO NOT SCALE DRAWING		SCALE 1:2	WEIGHT:	SHEET 3 OF 3