

NOTES: UNLESS OTHERWISE SPECIFIED

1. MATERIAL: 4140 STEEL CD HEAT TREAT TO 38-44 HRC
2. FINISH: N/A
3. DEBURR ALL SHARP EDGES
4. DIMENSIONS APPLY AFTER HEAT TREAT

REVISION	DESCRIPTION	APPROVAL
B	ADDED .03" CORNER RADIUS	A. LANE
C	COUNTERBORE DEPTH CHANGE	A. LANE

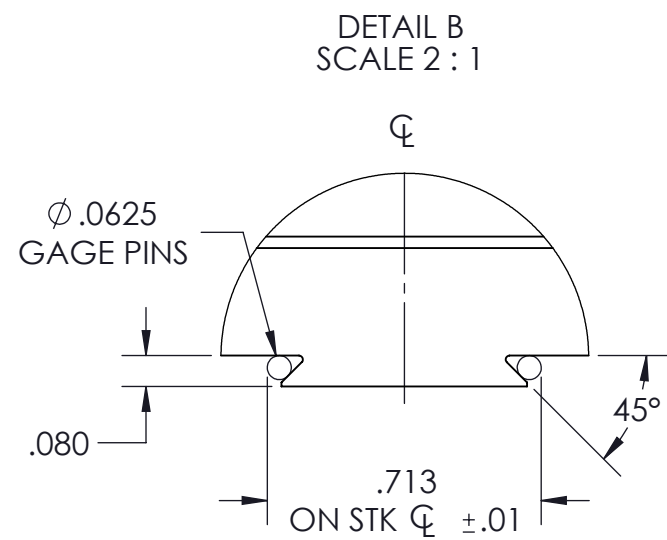
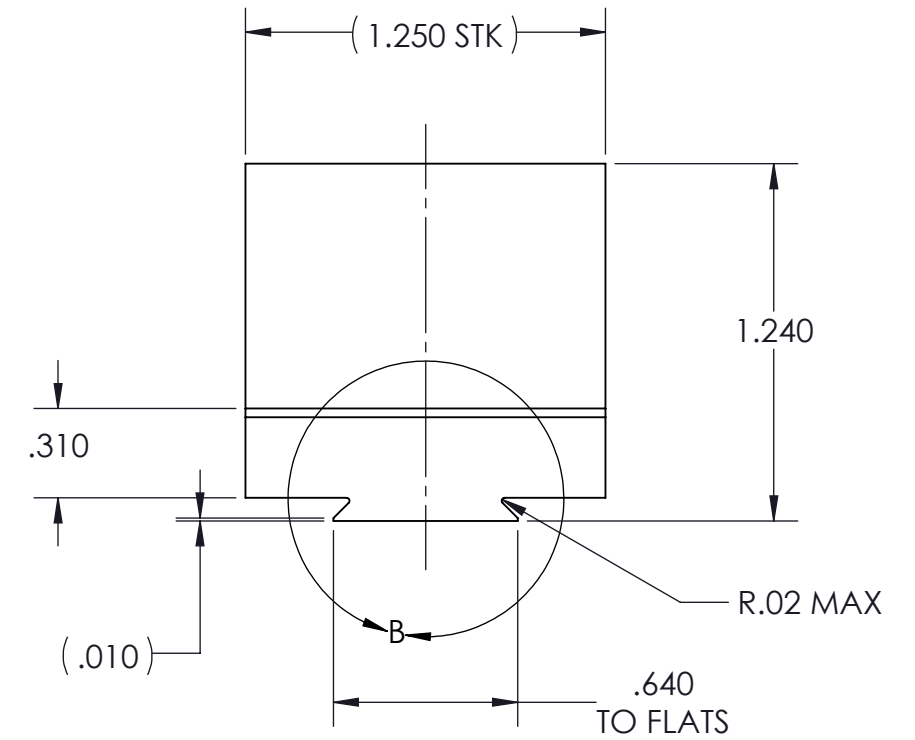
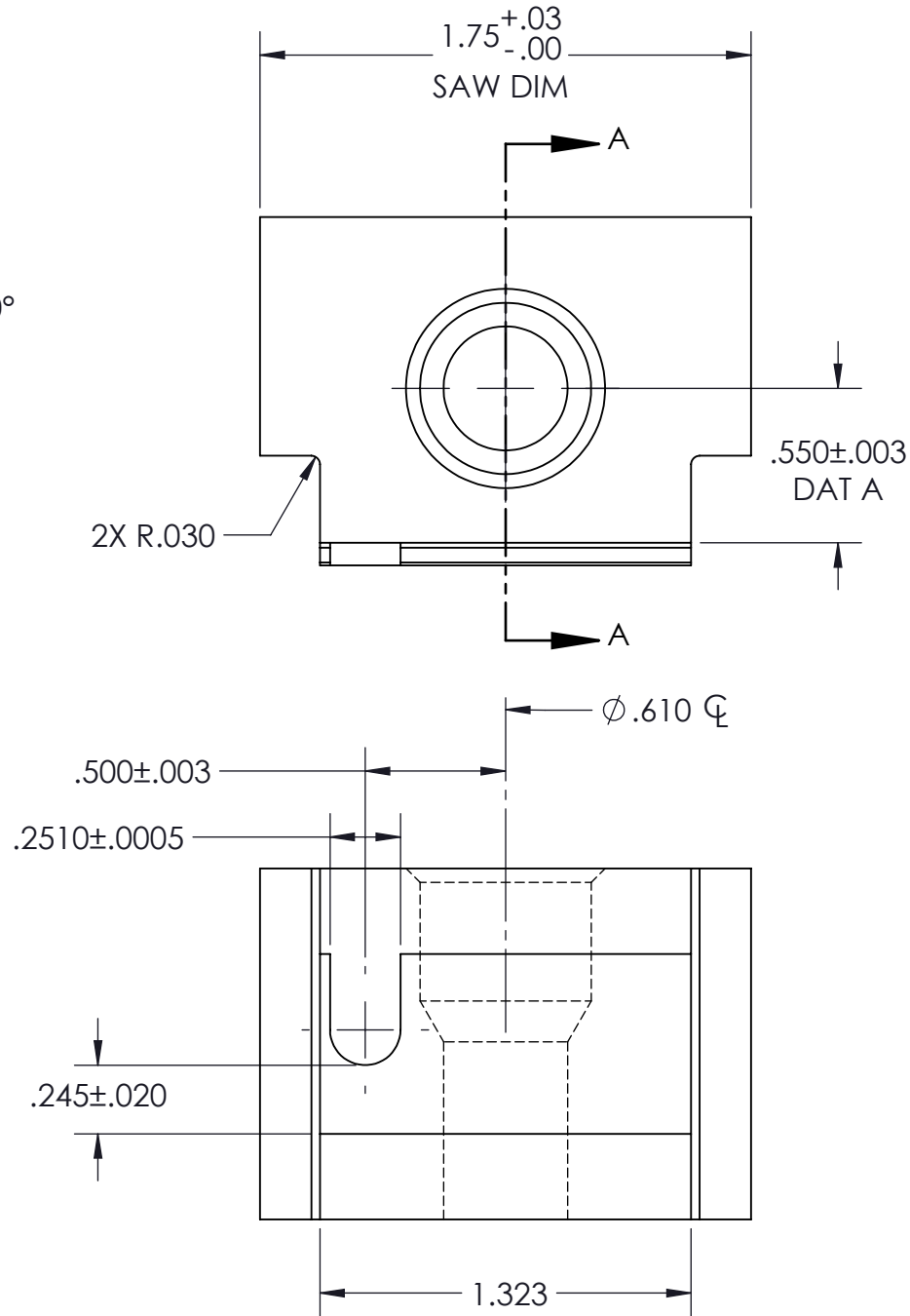
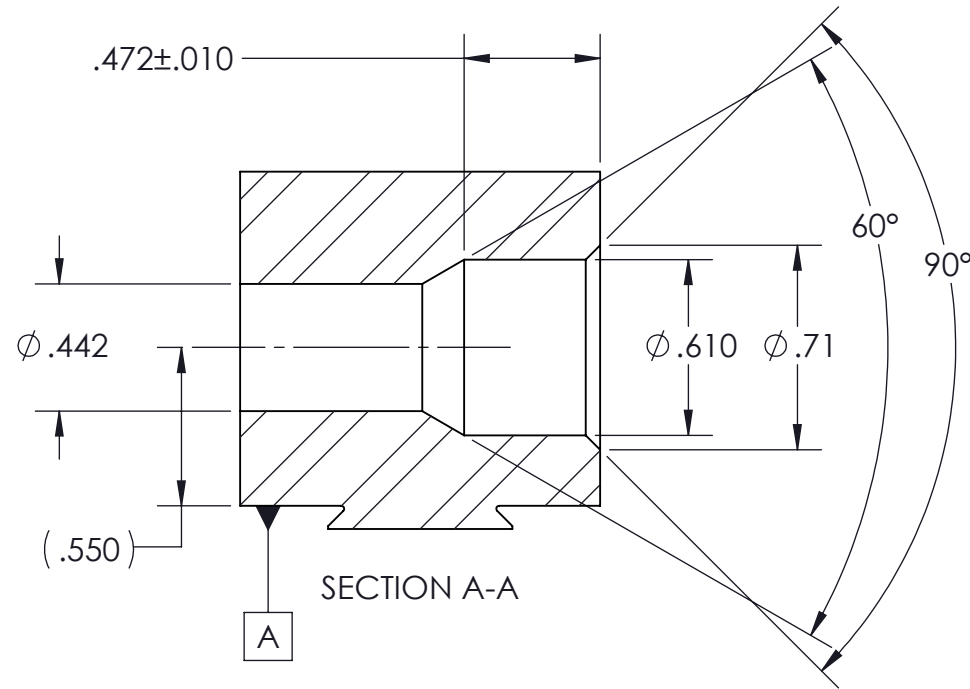

BLANK

INCH <small>DRAWN IN ACCORDANCE WITH ASME Y14.5-2009</small> PROPRIETARY AND CONFIDENTIAL <small>THE INFORMATION CONTAINED IN THIS DRAWING IS THE SOLE PROPERTY OF FIFTH AXIS, INC. ANY REPRODUCTION IN PART OR AS A WHOLE WITHOUT THE WRITTEN PERMISSION OF FIFTH AXIS, INC. IS PROHIBITED.</small>	TOLERANCES <small>UNLESS OTHERWISE SPECIFIED</small> X ± 0.1 .XX ± 0.01 .X ± 0.05 .XXX ± 0.005 ANGULAR ± 0.5° <small>THIRD ANGLE PROJECTION</small>	APPROVALS			<small>WWW.FIFTHAXIS.COM</small> 7140 ENGINEER ROAD SAN DIEGO, CA 92111 P (858) 505-0432 F (858) 505-9344
		<small>DRAWN BY</small> A. LANE	<small>DATE</small> 05/15/19		
<small>QUALITY</small> BRENT B.	<small>DATE</small> 10/6/2015	<small>FINAL</small> CHRIS T.	<small>DATE</small> 10/6/2015	<small>DESCRIPTION</small> 75MM VISE, TRUCK BLANK, X	<small>REV</small> C
<small>DO NOT SCALE DRAWING</small>		<small>SCALE</small> 1.5:1	<small>WEIGHT:</small>	<small>SHEET 3 OF 8</small>	

NOTES: UNLESS OTHERWISE SPECIFIED

1. MATERIAL: 4140 STEEL CD, HARDNESS: 38-42 HRC
2. FINISH: BLACK OXIDE
3. DEBURR ALL SHARP EDGES
4. OIL FINISH ALLOWED
5. ALL CHAMFER TOLERANCE $\pm .008$

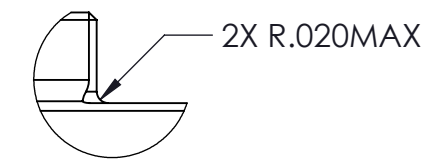
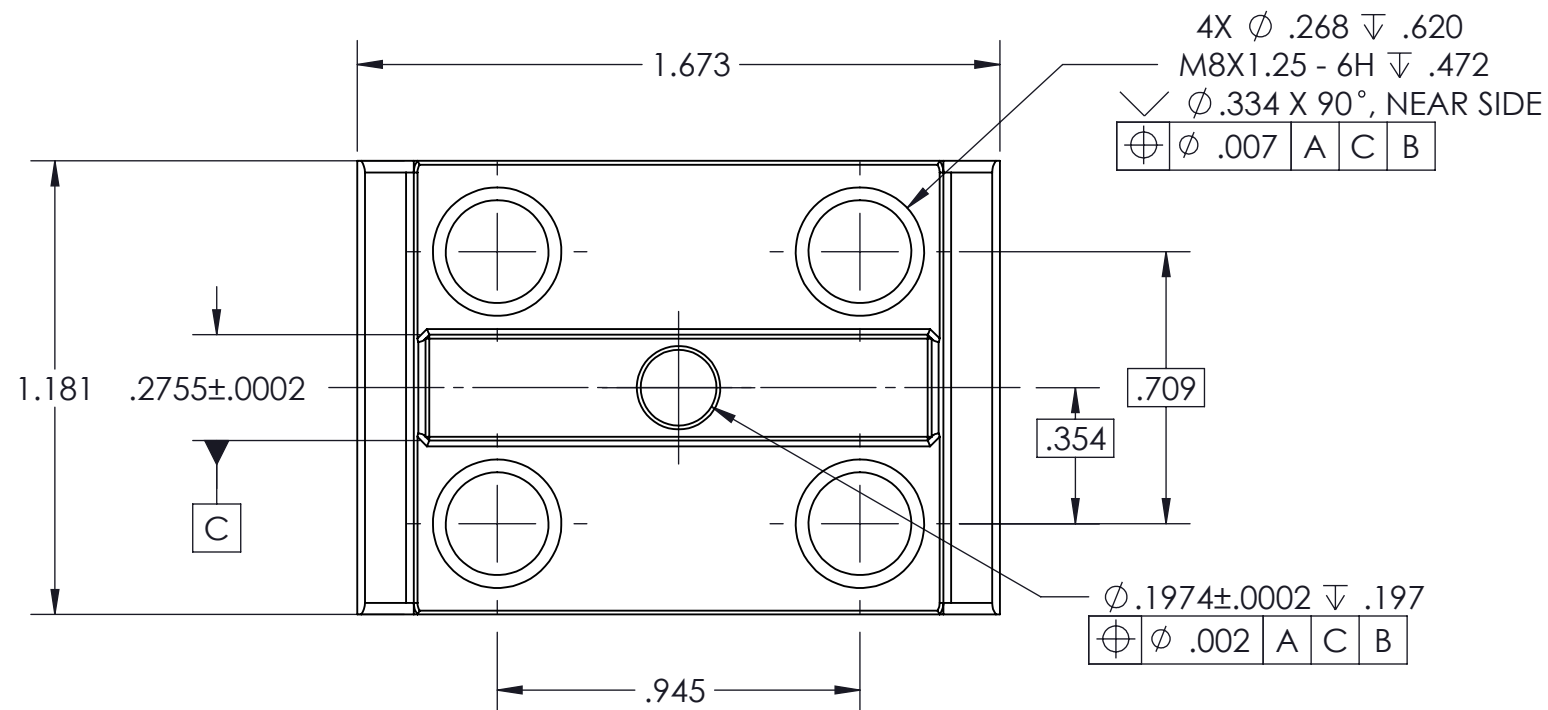

DETAIL C
SCALE 4:1

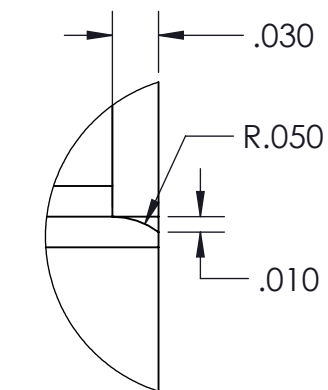

DETAIL D
SCALE 8:1
12X TYP

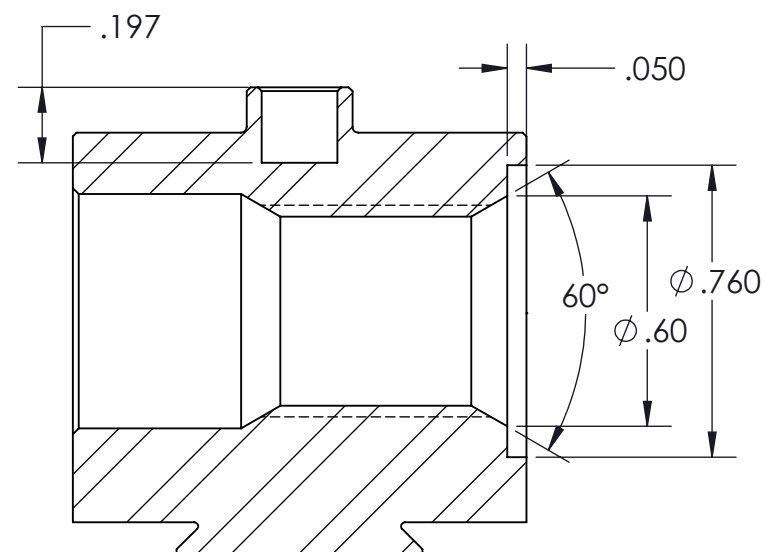

SECTION B-B

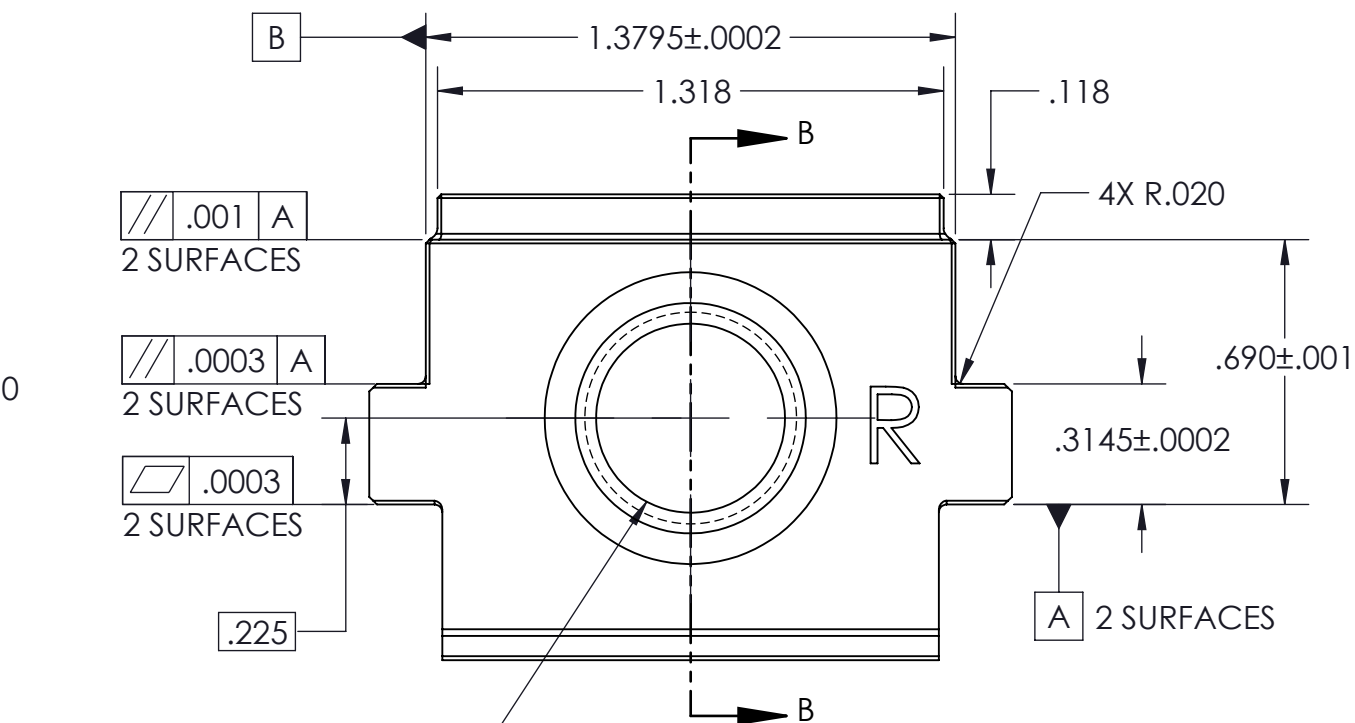

M14X1.5 - 6H RH THRU ALL
RIGHT HAND THREAD

Ø .003 A B C

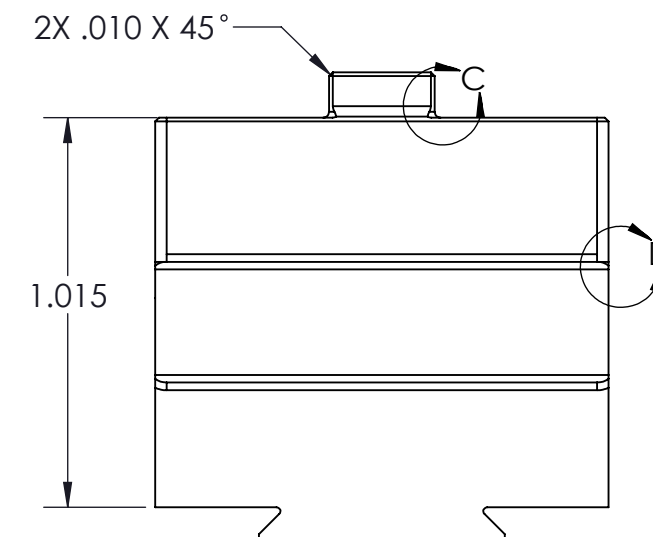

MILL OP 3

INCH <small>DRAWN IN ACCORDANCE WITH ASME Y14.5-2009</small> PROPRIETARY AND CONFIDENTIAL <small>THE INFORMATION CONTAINED IN THIS DRAWING IS THE SOLE PROPERTY OF FIFTH AXIS, INC. ANY REPRODUCTION IN PART OR AS A WHOLE WITHOUT THE WRITTEN PERMISSION OF FIFTH AXIS, INC. IS PROHIBITED.</small>	TOLERANCES <small>UNLESS OTHERWISE SPECIFIED</small> X ± 0.1 .XX ± 0.01 .X ± 0.05 .XXX ± 0.005 ANGULAR ± 0.5°	APPROVALS		WWW.FIFTHAXIS.COM 7140 ENGINEER ROAD SAN DIEGO, CA 92111 P (858) 505-0432 F (858) 505-9344
		DRAWN BY Y. RHEE MANUFACTURING 08/26/21	QUALITY FINAL A. LANE	
		DO NOT SCALE DRAWING		SCALE 2:1
		WEIGHT:		SHEET 4 OF 8

NOTES: UNLESS OTHERWISE SPECIFIED

1. MATERIAL: 4140 STEEL CD, HARDNESS: 38-42 HRC
2. FINISH: BLACK OXIDE
3. DEBURR ALL SHARP EDGES
4. OIL FINISH ALLOWED

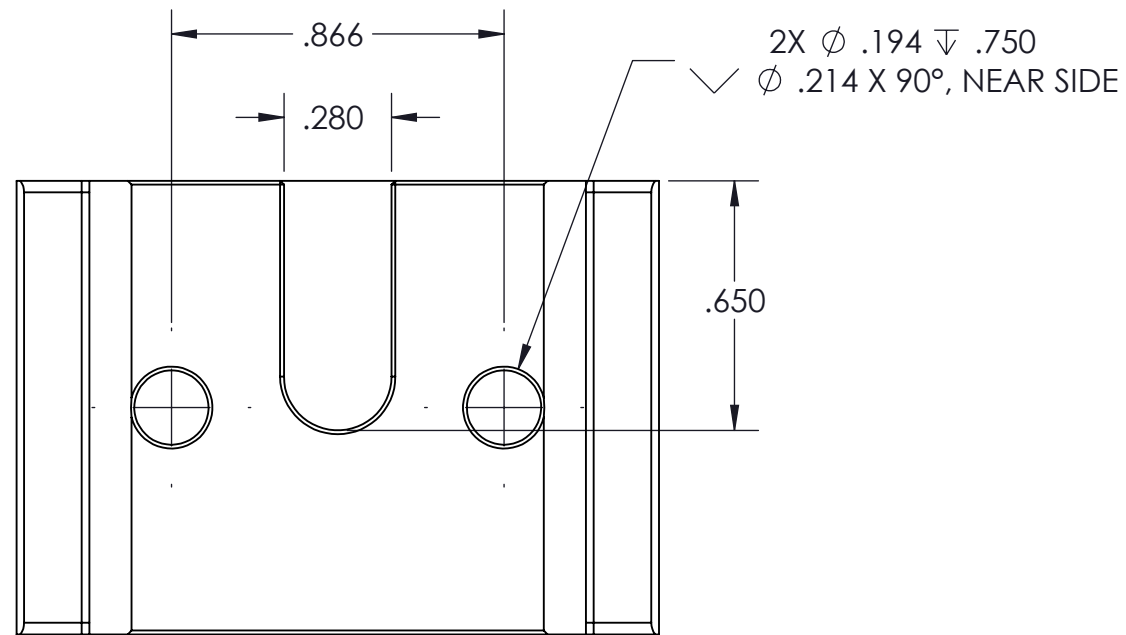
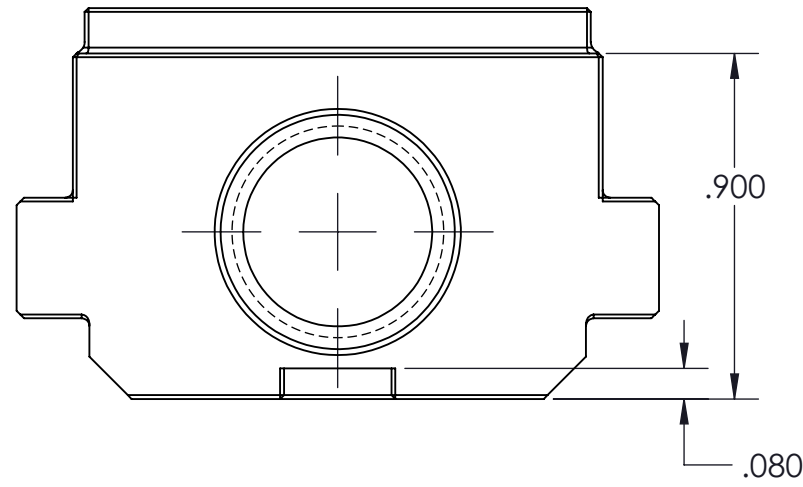

MILL OP 4

INCH <small>DRAWN IN ACCORDANCE WITH ASME Y14.5-2009</small>	TOLERANCES <small>UNLESS OTHERWISE SPECIFIED</small> X ± 0.1 .XX ± 0.01 .X ± 0.05 .XXX ± 0.005 ANGULAR ± 0.5°	APPROVALS		WWW.FIFTHAXIS.COM 7140 ENGINEER ROAD SAN DIEGO, CA 92111 P (858) 505-0432 F (858) 505-9344	
		DRAWN BY Y. RHEE	08/26/21		DESCRIPTION 75MM VISE, TRUCK, X
PROPRIETARY AND CONFIDENTIAL <small>THE INFORMATION CONTAINED IN THIS DRAWING IS THE SOLE PROPERTY OF FIFTH AXIS, INC. ANY REPRODUCTION IN PART OR AS A WHOLE WITHOUT THE WRITTEN PERMISSION OF FIFTH AXIS, INC. IS PROHIBITED.</small>	<small>THIRD ANGLE PROJECTION</small> 	QUALITY FINAL A. LANE	SIZE B	PART NO. V75100X-2R AND V75100X-2L	REV C
		DO NOT SCALE DRAWING	SCALE 2:1	WEIGHT:	SHEET 6 OF 8

NOTES: UNLESS OTHERWISE SPECIFIED

1. MATERIAL: 4140 STEEL CD, HARDNESS: 38-42 HRC
2. FINISH: BLACK OXIDE
3. DEBURR ALL SHARP EDGES
4. OIL FINISH REQUIRED

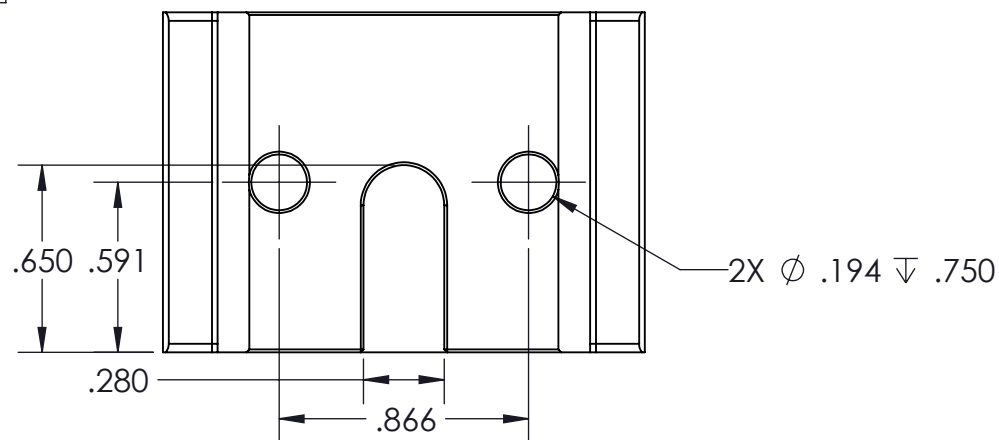
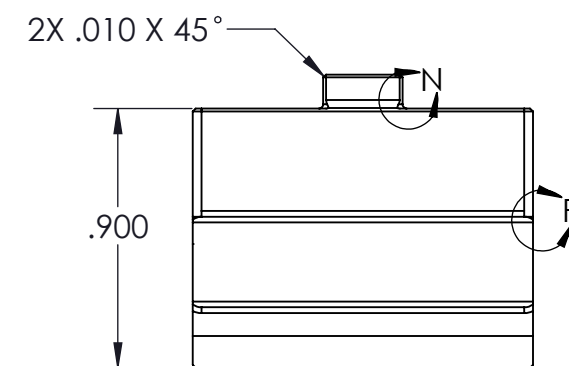
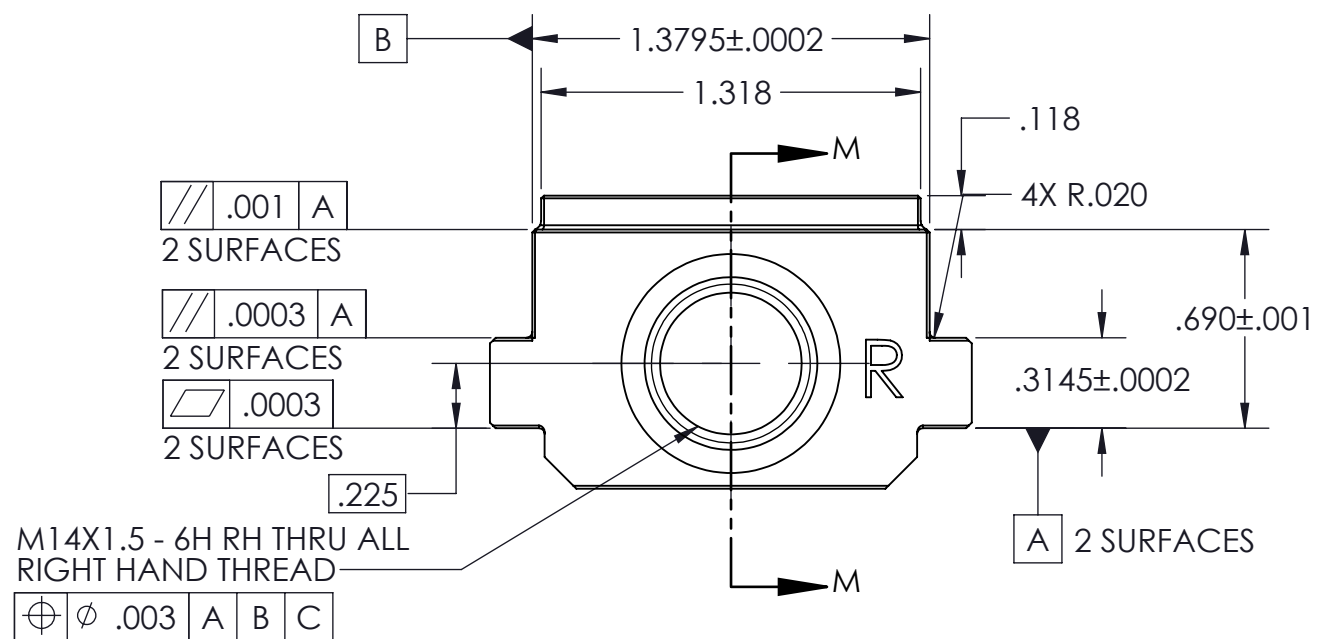
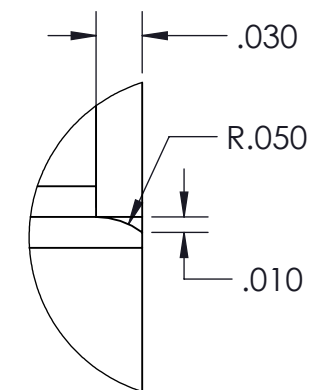
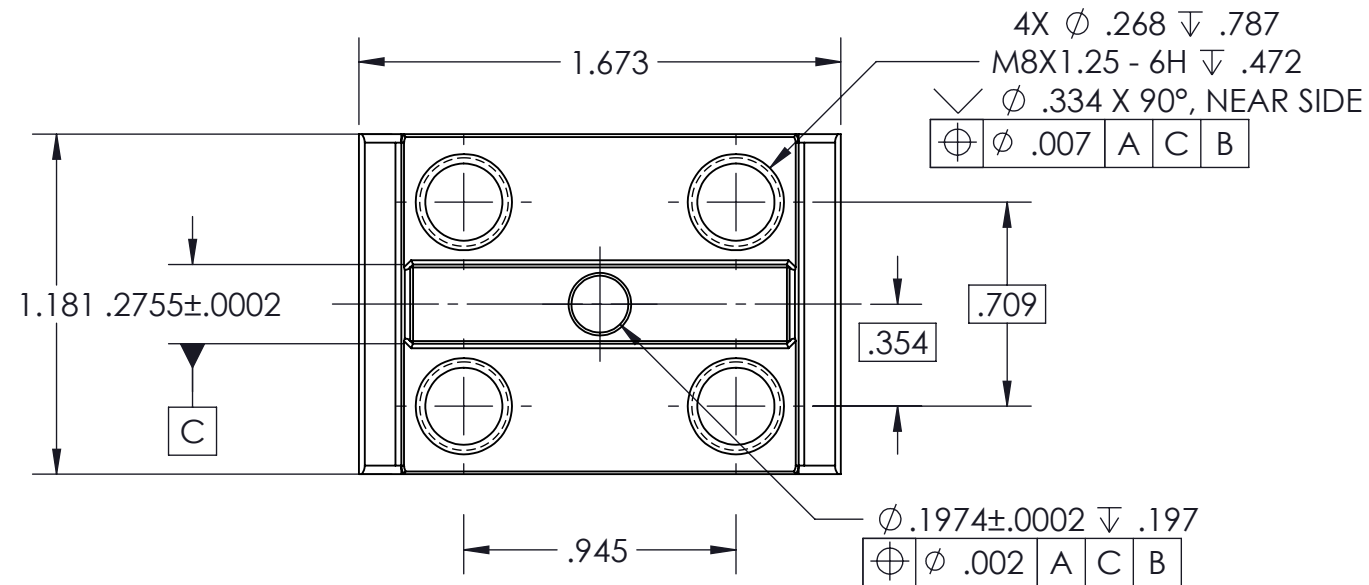
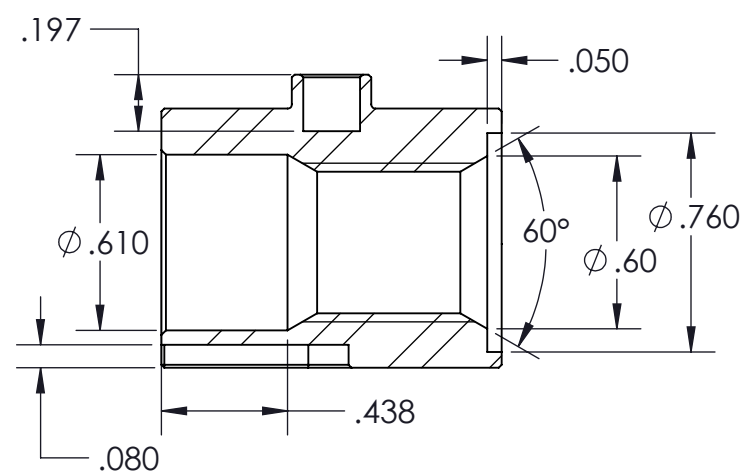
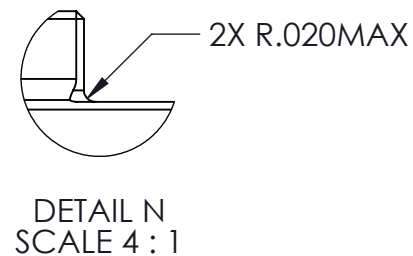

FINAL PRINT

REVISIONS				
ZONE	REV.	DESCRIPTION	DATE	APPROVED
B8	C	SOCKET COUNTERBORE DEPTH CHANGE	8/31/22	A. LANE

INCH <small>DRAWN IN ACCORDANCE WITH ASME Y14.5-2009</small> PROPRIETARY AND CONFIDENTIAL <small>THE INFORMATION CONTAINED IN THIS DRAWING IS THE SOLE PROPERTY OF FIFTH AXIS, INC. ANY REPRODUCTION IN PART OR AS A WHOLE WITHOUT THE WRITTEN PERMISSION OF FIFTH AXIS, INC. IS PROHIBITED.</small>	TOLERANCES <small>UNLESS OTHERWISE SPECIFIED</small> X ± 0.1 .XX ± 0.01 .X ± 0.05 .XXX ± 0.005 ANGULAR ± 0.5°	APPROVALS		WWW.FIFTHAXIS.COM 7140 ENGINEER ROAD SAN DIEGO, CA 92111 P (858) 505-0432 F (858) 505-9344
		<small>DRAWN BY</small> Y. RHEE	<small>DATE</small> 08/26/21	
<small>THIRD ANGLE PROJECTION</small> 	<small>QUALITY</small> FINAL	<small>SIZE</small> B	<small>PART NO.</small> V75100X-2R	<small>SCALE</small> 1.5:1
<small>DO NOT SCALE DRAWING</small>		<small>WEIGHT:</small>	<small>SHEET 7 OF 8</small>	